

Instruction Manual

RV3, RV5, RV8 and RV12 Rotary Vane Pumps

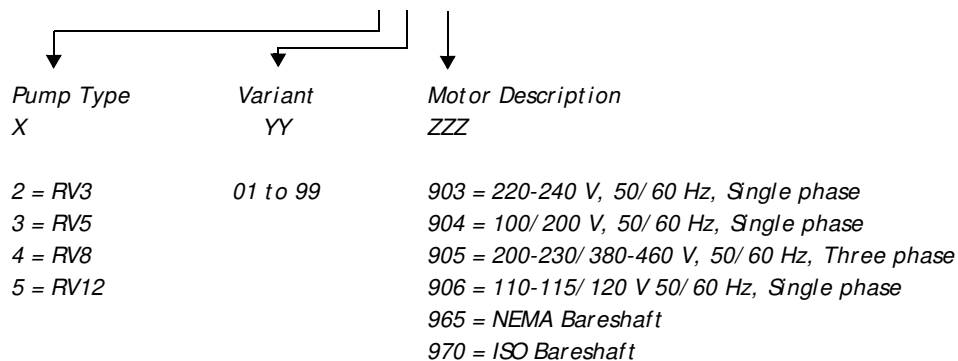

A 65X-YY-ZZZ





Declaration of Conformity

We, Edwards,
Manor Royal,
Crawley,
West Sussex, RH10 9LW, UK

declare under our sole responsibility, as manufacturer and person within the EU authorised to assemble the technical file, that the product(s)

RV Rotary Vacuum pumps:

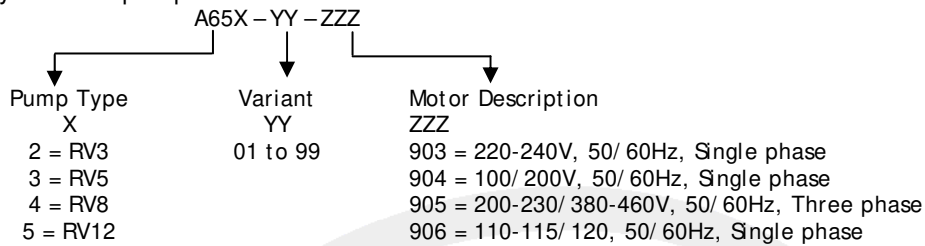

to which this declaration relates is in conformity with the following standard(s) or other normative document(s)

EN ISO 12100-2: 2003 + A1: 2009	Safety of Machinery. Basic Concepts, General Principles for Design. Technical Principals
EN1012-2:1996, A1: 2009	Compressors and Vacuum Pumps. Safety Requirements. Vacuum Pumps
EN61010-1: 2001*	Safety Requirements for Electrical Equipment for Measurement, Control and Laboratory Use. General Requirements
EN13463-1: 2009	Non-electrical equipment for use in potentially explosive atmospheres. Basic method and requirements
EN13463-5: 2003	Non-electrical equipment for use in potentially explosive atmospheres. Protection by constructional safety 'c'
EN60034-1: 2004	Rotating electrical machines. Rating and performance
C22.2 No77: 1995#	Motors with inherent overheating protection
C22.2 No100: 2004#	Motors and Generators
C22.2 61010-1-04: 2004	Safety requirements for electrical equipment for measurement, control and laboratory use –Part 1: General requirements
UL61010A: 2002	Safety requirements for electrical equipment for measurement, control and laboratory use –Part 1: General requirements
UL1004: 1994	Electric Motors

* 1-phase pumps only. *The pumps comply with EN 61010-1 when installed in accordance with the instruction manual supplied with the pumps.*

1-phase pumps only. *Canadian Standards Authority and Underwriters Laboratory.*

and fulfils all the relevant provisions of

2006/ 42/ EC	Machinery Directive
2006/ 95/ EC	Low Voltage Directive
2004/ 108/ EC	Electromagnetic Compatibility (EMC) Directive
94/ 9/ EC	ATEX Directive on use in Potentially Explosive Atmospheres

Note: This declaration covers all product serial numbers from the date this Declaration was signed onwards.



9 December 2009

Sa Abbaszadeh, Chief Technical Officer

Date and Place

This product has been manufactured under a quality system registered to ISO9001

Contents

Section	Page
1	Introduction 1
1.1	Scope and definitions 1
1.2	ATEX directive implications 2
1.3	Description 4
1.4	Performance modes and controls 4
1.4.1	Mode selector 4
1.4.2	Gas-ballast control 5
1.5	Construction 5
2	Technical data 7
2.1	Operating and storage conditions 7
2.2	Performance 7
2.2.1	General 7
2.2.2	Performance characteristics 11
2.3	Mechanical data 12
2.4	Noise and vibration data 12
2.5	Lubrication data 12
2.6	Electrical data: single-phase pumps 14
2.7	Electrical data: three-phase pumps 15
3	Installation 17
3.1	Safety 17
3.2	System design considerations 17
3.3	Unpack and inspect 18
3.4	Locate the pump 18
3.5	Fill the pump with oil 18
3.6	Fit the motor (bareshaft pumps only) 19
3.7	Electrical installation: single-phase pumps 19
3.7.1	Check and configure the motor 19
3.7.2	Connect the pump to your electrical supply 19
3.7.3	Check the direction of rotation 20
3.8	Electrical installation: three-phase pumps 22
3.8.1	Check and configure the motor 22
3.8.2	Connect the pump to your electrical supply 22
3.8.3	Check the direction of rotation 24
3.9	Inlet and outlet connections 24
3.10	Leak-test the system 25
4	Operation 27
4.1	ATEX directive implications 27
4.1.1	Introduction 27
4.1.2	Flammable/ pyrophoric materials 27
4.1.3	Gas purges 28
4.2	How to use the pump controls 28
4.2.1	Introduction 28
4.2.2	Mode selector 29
4.2.3	Gas-ballast control 29
4.3	Start-up procedure 30
4.4	To achieve ultimate vacuum 30
4.5	To pump condensable vapours 31
4.6	To decontaminate the oil 31

4.7	Unattended operation	31
4.8	Shut-down	32
5	Maintenance	33
5.1	Safety information	33
5.2	Maintenance plan	34
5.3	Check the oil-level	34
5.4	Replace the oil	35
5.5	Inspect and clean the inlet-filter	35
5.6	Inspect and clean the gas-ballast control	36
5.7	Clean the oil-level sight-glass	37
5.8	Clean the motor fan-cover and enclosure	38
5.9	Clean and overhaul the pump	38
5.10	Fit new blades	38
5.11	Test the motor condition	38
5.12	Fault-finding	38
5.12.1	Introduction	38
5.12.2	The pump has failed to start	38
5.12.3	The pump has failed to achieve the specified performance (has failed to reach ultimate vacuum)	39
5.12.4	The pump is noisy	39
5.12.5	The pump surface temperature is above 100°C	39
5.12.6	The vacuum is not fully maintained after the pump is switched off	39
5.12.7	The pumping speed is poor	40
5.12.8	There is an external oil leak	40
6	Storage and disposal	41
6.1	Storage	41
6.2	Disposal	41
7	Service and spares	43
7.1	Introduction	43
7.2	Service	43
7.3	Spares	43
7.4	Accessories	45
7.4.1	Introduction	45
7.4.2	Inlet catchpot	45
7.4.3	Inlet dust filter	45
7.4.4	Inlet desiccant trap	45
7.4.5	Inlet chemical trap	46
7.4.6	Foreline trap	46
7.4.7	Outlet mist filter	46
7.4.8	Gas-ballast adaptor	46
7.4.9	Gravity oil drain kit	46
7.4.10	Oil drain-extension	46
7.4.11	Exhaust nozzle kit	46
7.4.12	Vibration isolators	46
7.4.13	Solenoid operated gas-ballast valve	46
7.4.14	Solenoid operated pipeline valve	46
8	PFPE-prepared RV pumps	49
8.1	Summary	49
8.2	Installation	49
8.3	Operation	49
8.4	Maintenance	49
9	Bareshaft RV pumps	51
9.1	Description	51

9.2	Fit the motor to the bareshaft pump	51
-----	---	----

For return of equipment, complete the HSForms at the end of this manual.

Illustrations

Figure		Page
1	The RV pump	3
2	Performance characteristics in High Vacuum mode (pumping speed against inlet pressure)	11
3	Dimensions (mm)	13
4	Motor voltage configuration: single-phase pumps	21
5	Three-phase electrical connections: 200-230 V	23
6	Three-phase electrical connections: 380-460 V	23
7	Inlet-filter assembly	35
8	Gas-ballast control assembly	36
9	Sight-glass assembly	37
10	Accessories	47
11	Fit the motor to a bareshaft pump	52

Tables

Table		Page
1	Operating and storage conditions	7
2	General performance data	7
3	Performance data: High Vacuum mode	8
4	Performance data: High Throughput mode	9
5	Performance characteristics	10
6	Mechanical data	12
7	Noise and vibration data	12
8	Lubrication data	12
9	Electrical data (single-phase pumps with Item Numbers -903 or -906)	14
10	Electrical data (single-phase pumps with Item Numbers -904)	14
11	Electrical data (three-phase pumps with Item Numbers -905)	15
12	Maintenance plan	34
13	Spares and maintenance kits	44
14	Accessory item numbers	45

Associated publications

Publication title

Publication number

Vacuum pump and vacuum system safety

P300-20-000

Trademark credits

Fomblin® is a registered trademark of Ausimont SpA.

This page has been intentionally left blank.

1 Introduction

1.1 Scope and definitions

This manual provides installation, operation and maintenance instructions for the Edwards RV3, RV5, RV8 and RV12 Rotary Vane Pumps. You must use your pump as specified in this manual.

Read this manual before you install and operate your pump. Important safety information is highlighted as WARNING and CAUTION instructions; you must obey these instructions. The use of WARNINGS and CAUTIONS is defined below.



WARNING

Warnings are given where failure to observe the instruction could result in injury or death to people.

CAUTION

Cautions are given where failure to observe the instruction could result in damage to the equipment, associated equipment and process.

The units used throughout this manual conform to the SI international system of units of measurement

In accordance with the recommendations of IEC1010, the following warning labels are on the pump:



Warning – refer to accompanying documentation.



Warning – risk of electric shock.



Warning – hot surfaces.

1.2 ATEX directive implications



- This equipment is designed to meet the requirements of Group II Category 3 equipment in accordance with Directive 94/ 9/ EC of the European Parliament and the Council of 23rd March 1994 on the approximation of the laws of the Member States concerning equipment and protective systems intended for use in potentially explosive atmospheres. (The ATEX Directive).

The ATEX Category 3 applies in respect of potential ignition sources internal to the equipment. An ATEX Category has not been assigned in respect of potential ignition sources on the outside of the equipment as the equipment has not been designed for use where there is an external potentially explosive atmosphere.

There is no potential source of ignition within the pump during normal operation but there may be potential sources of ignition under conditions of predicted and rare malfunction as defined in the Directive. Accordingly, although the pump is designed to pump flammable materials and mixtures, operating procedures should ensure that under all normal and reasonably predicted conditions, these materials and mixtures are not within explosive limits. Category 3 is considered appropriate for the avoidance of ignition in the case of a rare malfunction which allows flammable materials or mixtures to pass through the pump while within their explosive limits.

- When flammable or pyrophoric materials are present within the equipment you must:
 - Not allow air to enter the equipment.
 - Ensure that the system is leak tight.
- For further information, please contact Edwards: refer to the Addresses page at the end of this manual for details of your nearest Edwards company.

Figure 1 - The RV pump

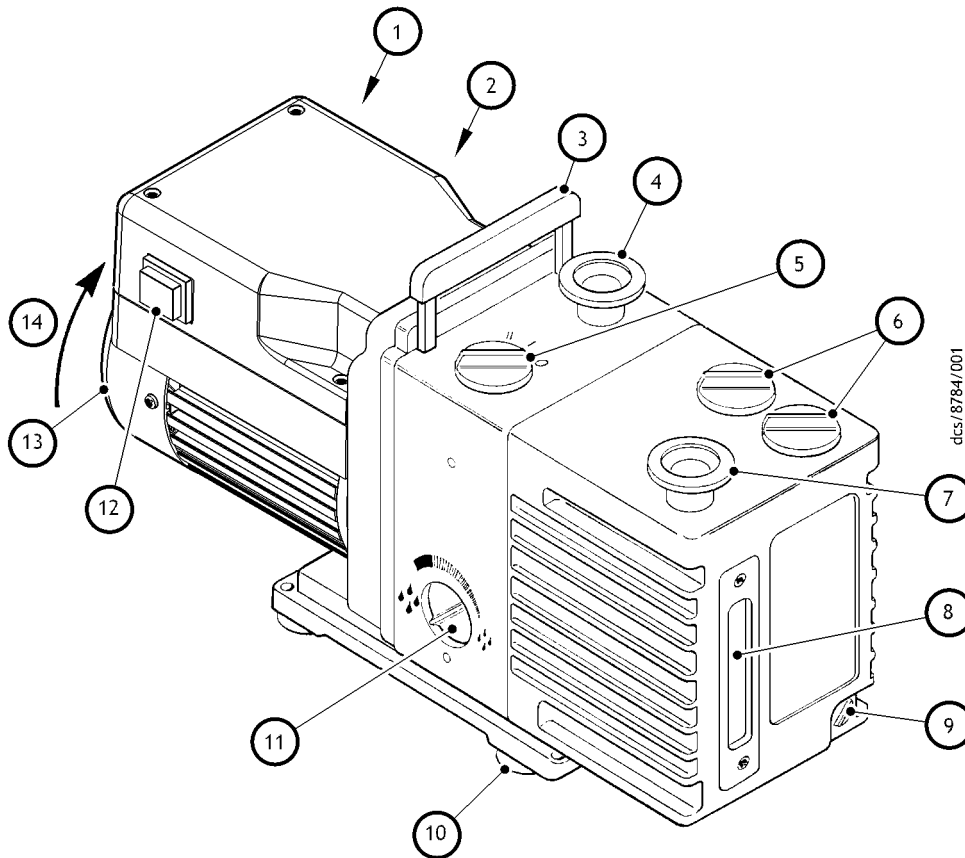

- | | |
|--|---|
| <ul style="list-style-type: none"> 1. Electrical inlet-connector 2. Voltage indicator 3. Lifting handle* 4. NW25 inlet-port 5. Gas-ballast control 6. Oil filler-plug 7. NW25 outlet-port | <ul style="list-style-type: none"> 8. Oil-level sight-glass 9. Oil drain-plug 10. Rubber feet (4 off) 11. Mode selector 12. On-off switch† 13. Motor fan-cover 14. Correct direction of rotation |
|--|---|

* RV3 and RV5 pumps only; a lifting bracket is fitted to RV8 and RV12 pumps.

† Single-phase pumps only.

Note: Single-phase RV3/ RV5 pump shown.

1.3 Description

The Edwards RV rotary vane pump is shown in [Figure 1](#). Refer to [Figure 1](#) for item numbers in brackets in the following descriptions. The RV pumps are two-stage, oil-sealed, sliding-vane vacuum pumps. The pump has NW25 inlet (4) and outlet (7) ports, a gas-ballast control (5) and a mode selector (11). When the pump is switched off, an inlet-valve seals the inlet and prevents the suck-back of air and oil into the vacuum system.

The RV3 and RV5 pumps have a retractable lifting handle (3). The RV8 and the RV12 pumps are fitted with a lifting bracket for use with suitable lifting equipment.

An oil-pump delivers pressurised oil to the vacuum pumping mechanism in the RV pump. You can inspect the level and condition of the oil in the oil-box through a sight-glass (8). Two oil filler-plugs (6) and an oil drain-plug (9) are provided on the oil-box.

The pump mechanism is driven directly by a single-phase or three-phase electric motor through a flexible motor-coupling. The motor is totally enclosed and is cooled by the motor cooling-fan which directs air along the motor fins. The pumps are cooled by an additional fan attached to the motor-coupling.

Single-phase motors are fitted with an on/ off switch (12) and a thermal overload device. When the motor is too hot, the thermal overload device switches off the pump. The thermal overload device has an automatic reset; when the motor cools down, the device resets and (unless you have incorporated suitable control equipment which must be manually reset: see [Section 3.7.2](#) and [Section 3.8.2](#)), the motor will restart.

As of the end of 2009 improved motors have been fitted to RV pumps. These motors benefit from being fitted with an aluminium terminal box and externally accessible voltage change over switches. The introduction of these motors has resulted in the range of motors covering all voltage and frequency conditions being reduced from four variants to two. All motors are interchangeable and pump performance is not affected.

The pump is mounted on a base plate on rubber feet (10). Details of suitable vibration isolators and other accessories are provided in [Section 7.4](#).

Refer to [Section 8](#) for additional information if your pump is PFPE-prepared.

1.4 Performance modes and controls

The pump has two controls: the mode selector (11) and the gas-ballast control (5). Six possible combinations of these controls allow for a wide choice of operating characteristics so you can optimise the performance of the pump for a given application.

1.4.1 Mode selector

The mode selector has two positions; refer to [Section 4.2](#) to select these positions. Throughout the rest of this manual, the following convention is used:

- The High Vacuum mode is specified by the ♠ symbol.
- The High Throughput mode is specified by the ♣ symbol.

With the mode selector set to High Vacuum mode ♠, pressurised oil is fed to the low vacuum stage only. In this mode of operation, the pump provides the best possible ultimate vacuum.

With the mode selector set to High Throughput mode ♣, pressurised oil is fed to the high vacuum and low vacuum stages. In this mode of operation, the pump can sustain long-term high inlet pressures.

1.4.2 Gas-ballast control

To pump high vapour loads, gas-ballast is delivered into the pump to prevent condensation of the vapour carried by the pumped gases.

Air can be introduced to the low vacuum stage through the gas-ballast valve. Alternatively, an inert gas such as nitrogen can be supplied through a suitable external valve.

The gas-ballast control has three positions:

- Closed (position '0')
- Low flow (position 'I')
- High flow (position 'II').

1.5 Construction

The pump-shafts and rotors are made of high-grade cast-iron. The pump-body and oil-box are made from cast-aluminium. All surfaces of the pump which are exposed to the pumped gases are free from copper, zinc and cadmium.

Other materials of construction include fluorocarbon elastomer, nitrile, silicon, chemically-resistant polymers, nickel and stainless steel.

This page has been intentionally left blank.

2 Technical data

Note: To comply with CSA standards, the pump must be installed and used indoors, and within the operating conditions specified in Table 1 below.

2.1 Operating and storage conditions

Table 1 - Operating and storage conditions

Parameter	Reference data
Ambient temperature range (operation)	12 to 40°C
Ambient temperature range (storage)	-30 to 70°C
Normal surface temperature of the pump-body *	50 to 70°C
Maximum humidity (operation)	90%RH
Maximum altitude (operation)	2000 m
Pollution degree	2
Installation category	II

* At ultimate vacuum, with ambient temperature of 20°C.

2.2 Performance

2.2.1 General

Note: In Table 2 and Table 3, total pressures have been measured by a capacitance diaphragm gauge on a vacuum chamber without a cold trap, as specified by Pneurop Standard 6602 (1979).

Table 2 - General performance data

Parameter	Reference data			
High Vacuum mode ◆ performance	See Table 3			
High Throughput mode ◆ performance	See Table 4			
Suckback protection	1×10^{-5} mbar l s ⁻¹ , 1×10^{-3} Pa l s ⁻¹			
Maximum initial pressure rise with no gas-ballast flow	1×10^{-1} mbar, 10 Pa			
	RV3	RV5	RV8	RV12
Maximum displacement: m ³ h ⁻¹				
50 Hz electrical supply	3.7	5.8	9.7	14.2
60 Hz electrical supply	4.5	5.0	11.7	17.0
Maximum pumping speed (Pneurop 6602, 1979): m ³ h ⁻¹				
50 Hz electrical supply	3.3	5.1	8.5	12.0
60 Hz electrical supply	3.9	6.2	10.0	14.2
Maximum permitted inlet pressure and gas-ballast inlet pressure				
bar gauge	0.5	0.5	0.5	0.5
Pa	1.5×10^5	1.5×10^5	1.5×10^5	1.5×10^5
Maximum permitted outlet pressure				
bar gauge	1	1	1	1
Pa	2×10^5	2×10^5	2×10^5	2×10^5



Table 3 - Performance data: High Vacuum mode

HIGH VACUUM MODE ♦										
Parameter	Units	RV3		RV5		RV8		RV12		
		1-phase	3-phase	1-phase	3-phase	1-phase	3-phase	1-phase	3-phase	
Gas-ballast control closed (position '0')	Ultimate total pressure	mbar	2×10^{-3}		2×10^{-3}		2×10^{-3}		2×10^{-3}	
		Pa	2×10^{-1}		2×10^{-1}		2×10^{-1}		2×10^{-1}	
Gas-ballast control low flow (position 'I')	Ultimate total pressure	mbar	3×10^{-2}		3×10^{-2}		3×10^{-2}		3×10^{-2}	
		Pa	3		3		3		3	
Gas-ballast flow	l min^{-1}	5		5		5		5		
Maximum water vapour pumping rate	kg h^{-1}	0.06	0.04	0.06	0.04	0.06	0.04	0.06	0.04	
Maximum water vapour inlet pressure	mbar	27	18	16	11	10	7	7	5	
	Pa	2.7×10^3	1.8×10^3	1.6×10^3	1.1×10^3	1×10^3	7×10^2	7×10^2	5×10^2	
Gas-ballast control high flow (position 'II')	Ultimate total pressure	mbar	1.2×10^{-1}		1×10^{-1}		6×10^{-2}		6×10^{-2}	
		Pa	1.2×10^1		1×10^1		6		6	
Gas-ballast flow	l min^{-1}	14		14		16		16		
Maximum water vapour pumping rate	kg h^{-1}	0.22	0.12	0.22	0.12	0.22	0.20	0.29	0.25	
Maximum water vapour inlet pressure	mbar	80	54	50	32	38	34	32	28	
	Pa	8×10^3	5.4×10^3	5×10^3	3.2×10^3	3.8×10^3	3.4×10^3	3.2×10^3	2.8×10^3	

Table 4 - Performance data: High Throughput mode

HIGH THROUGHPUT MODE									
Parameter	Units	RV3		RV5		RV8		RV12	
		1-phase	3-phase	1-phase	3-phase	1-phase	3-phase	1-phase	3-phase
Gas-ballast control closed (position '0')									
Ultimate total pressure	mbar	3×10^{-2}		3×10^{-2}		3×10^{-2}		3×10^{-2}	
	Pa	3		3		3		3	
Gas-ballast control low flow (position 'I')									
Ultimate total pressure	mbar	6×10^{-2}		6×10^{-2}		4×10^{-2}		4×10^{-2}	
	Pa	6		6		4		4	
Gas-ballast flow	l min ⁻¹	5		5		5		5	
Maximum water vapour pumping rate	kg h ⁻¹	0.06	0.04	0.06	0.04	0.06	0.04	0.06	0.04
Maximum water vapour inlet pressure	mbar	27	18	16	11	10	7	7	5
	Pa	2.7×10^3	1.8×10^3	1.6×10^3	1.1×10^3	1×10^3	7×10^2	7×10^2	5×10^2
Gas-ballast control high flow (position 'II')									
Ultimate total pressure	mbar	1.2×10^{-1}		1×10^{-1}		6×10^{-2}		6×10^{-2}	
	Pa	1.2×10^1		1×10^1		6		6	
Gas-ballast flow	l min ⁻¹	14		14		16		16	
Maximum water vapour pumping rate	kg h ⁻¹	0.22	0.12	0.22	0.12	0.22	0.20	0.29	0.25
Maximum water vapour inlet pressure	mbar	80	54	50	32	38	34	32	28
	Pa	8×10^3	5.4×10^3	5×10^3	3.2×10^3	3.8×10^3	3.4×10^3	3.2×10^3	2.8×10^3

Table 5 - Performance characteristics

MODE SELECTOR POSITION	GAS BALLAST CONTROL					
	Closed (position '0')		Low flow (position 'I')		High flow (position 'II')	
High Vacuum mode 	Ultimate total pressure		Ultimate total pressure		Ultimate total pressure	
	mbar	Pa	mbar	Pa	mbar	Pa
	2×10^{-3}	2×10^{-1}	3×10^{-2}	3	1.2×10^{-1} (RV3) 1.0×10^{-1} (RV5) 6×10^{-2} (RV8/ 12)	1.2×10^1 (RV3) 1.0×10^1 (RV5) 6.0 (RV8/ 12)
	Use for the best ultimate pressure		Maximum water vapour pumping rate		Maximum water vapour pumping rate	
			1-phase pumps	3-phase pumps	1-phase pumps	3-phase pumps
			0.06 kg h ⁻¹	0.04 kg h ⁻¹	0.22 kg h ⁻¹ (RV3/ 5/ 8) 0.29 kg h ⁻¹ (RV12)	0.12 kg h ⁻¹ (RV3/ 5) 0.20 kg h ⁻¹ (RV8) 0.25 kg h ⁻¹ (RV12)
High Throughput mode 	Ultimate total pressure		Ultimate total pressure		Ultimate total pressure	
	mbar	Pa	mbar	Pa	mbar	Pa
	3×10^{-2}	3	6×10^{-2} (RV3/ 5) 4×10^{-2} (RV8/ 12)	6 (RV3/ 5) 4 (RV8/ 12)	1.2×10^{-1} (RV3) 1.0×10^{-1} (RV5) 6×10^{-2} (RV8/ 12)	1.2×10^1 (RV3) 1.0×10^1 (RV5) 6.0 (RV8/ 12)
	Use for continuous inlet pressure above 50 mbar/ 5×10^3 Pa		Maximum water vapour pumping rate		Maximum water vapour pumping rate	
			1-phase pumps	3-phase pumps	1-phase pumps	3-phase pumps
			0.06 kg h ⁻¹	0.04 kg h ⁻¹	0.22 kg h ⁻¹ (RV3/ 5/ 8) 0.29 kg h ⁻¹ (RV12)	0.12 kg h ⁻¹ (RV3/ 5) 0.20 kg h ⁻¹ (RV8) 0.25 kg h ⁻¹ (RV12)

2.2.2 Performance characteristics

Note: The performance characteristics described below are for use with hydrocarbon oil.

The positions of the mode selector and the gas-ballast control define the performance characteristics of the pump. These performance characteristics are listed fully in Table 3 and Table 4.

Table 5 gives the ultimate vacuum and maximum water vapour inlet pressure for each of the six possible combinations of control positions. The curves 0, I, and II in Figure 2 show the relationship between inlet pressure and pumping speed for High Vacuum mode.

Figure 2 - Performance characteristics in High Vacuum mode (pumping speed against inlet pressure)

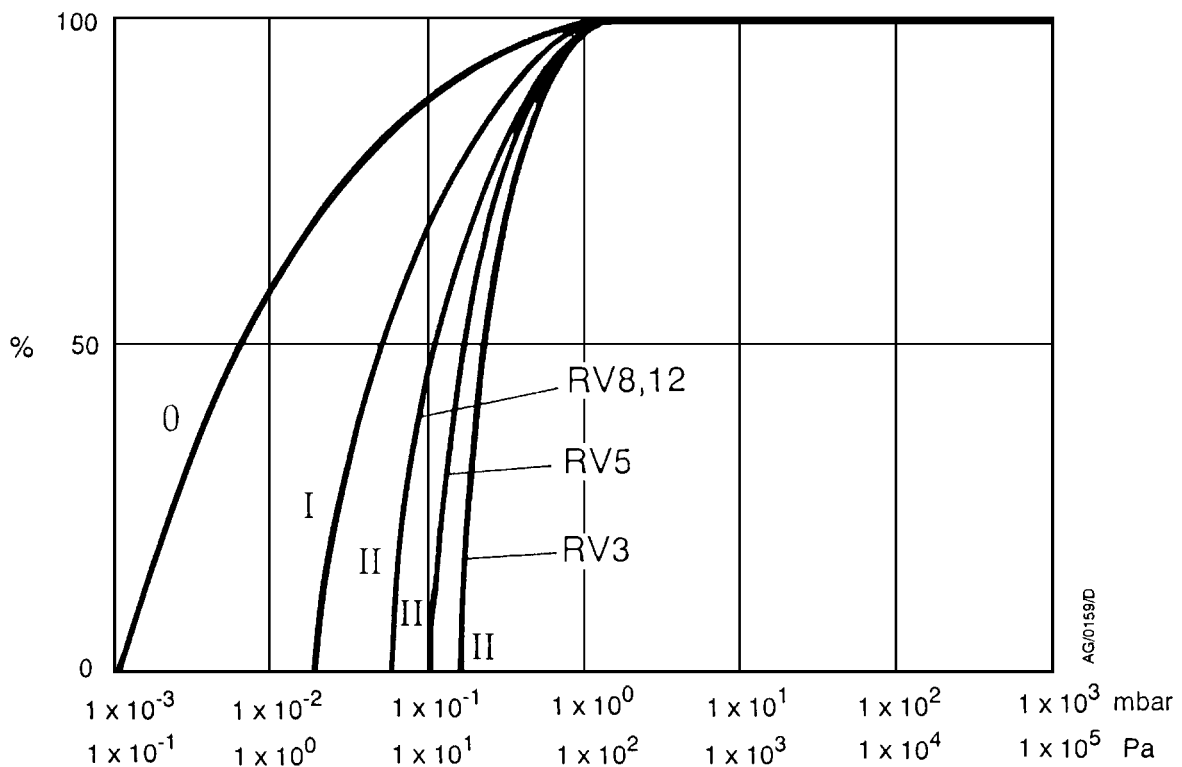

2.3 Mechanical data

Table 6 - Mechanical data

Parameter	Reference data			
Dimensions	See Figure 3			
Degree of protection (IEC 34-5: 1981)				
Single-phase pumps	IP44			
Three-phase pumps	IP54			
Maximum tilt angle	10°			
Motor rotational speed				
50 Hz electrical supply	1470 r min ⁻¹			
60 Hz electrical supply	1760 r min ⁻¹			
Maximum mass	RV3	RV5	RV8	RV12
Pumps with motor, without oil	23.3 kg	23.2 kg	26.0 kg	26.3 kg
Bareshaft pumps	14.0 kg	14.0 kg	16.5 kg	17.5 kg

2.4 Noise and vibration data

Table 7 - Noise and vibration data

Parameter	Reference data
Sound pressure*	
Single-phase pumps	48 dB (A)
Three-phase pumps	50 dB (A)
Vibration severity†	
Single-phase pumps	Class 1C
Three-phase pumps	Class 1C

* Measured at ultimate vacuum 1 metre from the end of the pump to ISO 11201, High Vacuum mode S, 50 Hz operation.

† Measured at the inlet port to ISO 2372 (1974)

2.5 Lubrication data

Note: Edwards Material Safety Data sheets for the rotary pump oils are available on request.

Table 8 - Lubrication data

Parameter	Reference data			
Recommended oil*				
Hydrocarbon-prepared pumps	Edwards Ultragrade 19			
PFPE-prepared pumps	Krytox 1506 or Fomblin 06/ 6			
Oil capacity	RV3	RV5	RV8	RV12
Maximum	0.70 litres	0.70 litres	0.75 litres	1.00 litres
Minimum	0.42 litres	0.42 litres	0.45 litres	0.65 litres

* To operate the pump when the ambient temperature is outside the limits specified in Section 2.1, or to optimise the pump performance when you pump condensable vapours, you may need to use a different oil.

Figure 3 - Dimensions (mm)

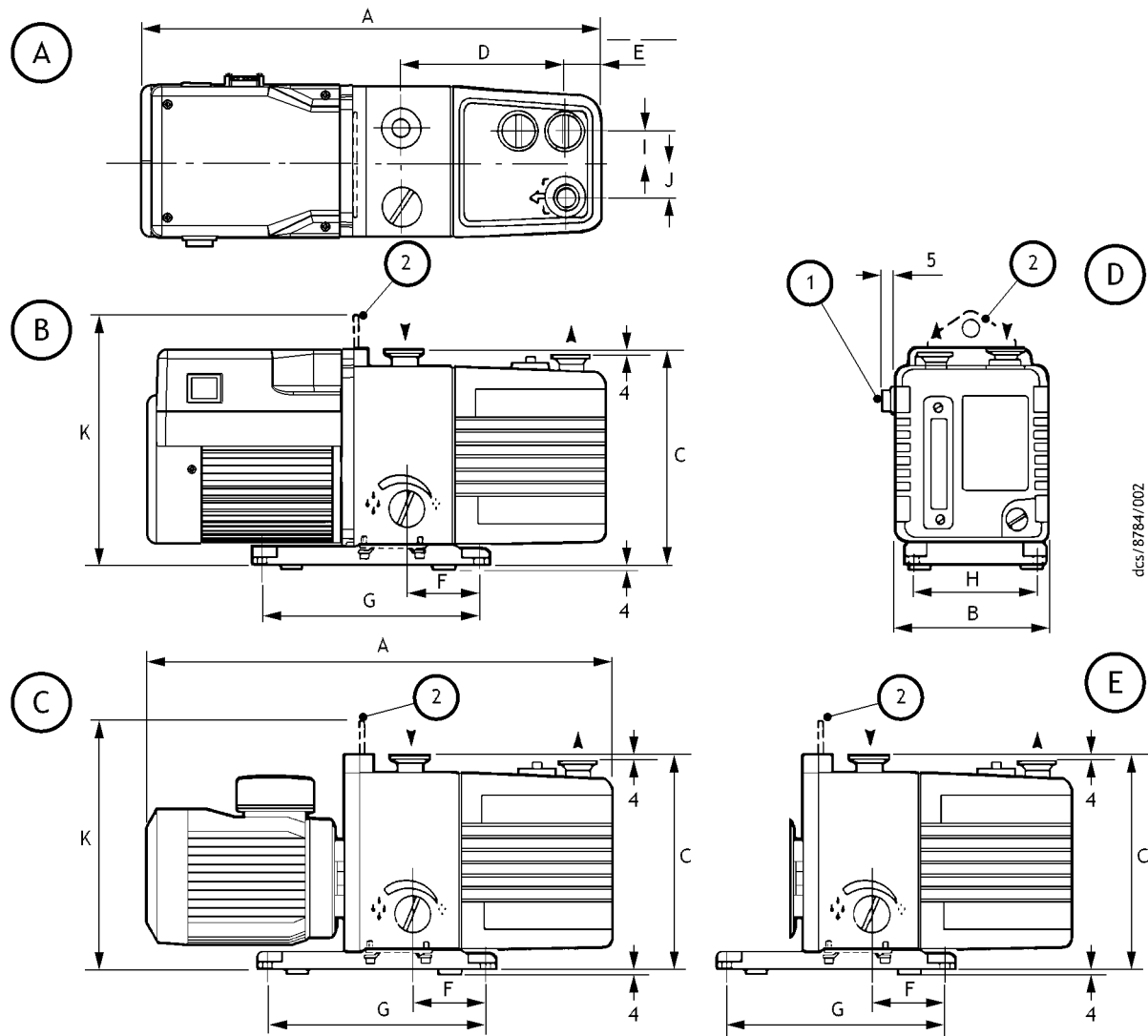

1. On-off switch (single-phase pumps only)
2. Lifting bracket (Not fitted to RV3 and RV5 pumps: a lifting handle is fitted instead)

- A. Top view of single-phase pump
- B. Side view of single-phase pump
- C. Side view of three-phase pump
- D. Front view of single-phase pump
- E. Side view of bare shaft pump

Pump	A*	A†	B	C	D	E	F	G	H	I	J	K
RV3	430	429	158	225	127	29	78	230	120	37	32	–
RV5	430	429	158	225	127	29	78	230	120	37	32	–
RV8	470	429	158	225	161	35	78	230	120	37	32	261
RV12	439	429	158	225	181	35	78	230	120	37	32	261

* Single-phase pumps.

† Three-phase pumps.

2.6 Electrical data: single-phase pumps

Note: We recommend that you use fuses of the maximum ratings specified in [Table 9](#) and [Table 10](#). You must not use fuses of a higher rating.

The dual-voltage, dual-frequency motor is designed for a single-phase electrical supply and is suitable for 50 Hz or 60 Hz operation. The motor can be manually switched between nominal supply voltages of 110–120 V and 220–240 V (refer to [Section 3.7.1](#)).

When you start a cold pump, the motor will draw the start-up current shown in [Table 9](#) and [Table 10](#) for up to several seconds, so you must use a slow-blow fuse to prevent unnecessary fuse failure during pump start-up. Within five minutes, as the oil in the pump warms up, the current drawn will slowly reduce to the full load current specified in [Table 9](#) and [Table 10](#).

Table 9 - Electrical data (single-phase pumps with Item Numbers -903 or -906)

Pump	Nominal supply (V)	Frequency (Hz)	Power (W)	Full load current (A)	Start-up current (A)	Maximum fuse rating (A)
RV3 and RV5	220–240	50	250	2.7	17.0	5
	230–240	60	300	2.1	17.0	5
	110	50	250	4.6	30.8	10
	115–120	60	300	4.4	30.8	10
RV8 and RV12	220–240	50	450	3.4	17.0	5
	230–240	60	550	3.4	18.0	5
	110	50	450	7.8	34.0	13
	115–120	60	550	6.9	30.8	13

Table 10 - Electrical data (single-phase pumps with Item Numbers -904)

Pump	Nominal supply (V)	Frequency (Hz)	Power (W)	Full load current (A)	Start-up current (A)	Maximum fuse rating (A)
RV3 and RV5	200	50	250	2.7	17.0	5
	200–210	60	300	2.1	17.0	5
	100	50	250	5.4	30.8	10
	100–105	60	300	4.6	30.8	10
RV8 and RV12	200	50	450	3.4	17.0	5
	200–210	60	550	3.4	20.6	5
	100	50	450	7.6	40.0	13
	100–105	60	550	6.9	30.8	13

Note: The fuse type chosen should be either a time delay type CC or a type M, or (in the UK) they should be to BS 88.

2.7 Electrical data: three-phase pumps

The dual-voltage, dual-frequency motor is designed for a three-phase electrical supply and is suitable for 50 Hz or 60 Hz operation. The motor can be manually switched between nominal supply voltages of 220–240 V and 380–460 V (refer to [Section 3.8.1](#)). Pumps are supplied preset for nominal 380–460 V electrical supplies.

When you start a cold pump, the motor will draw the start-up current shown in [Table 11](#) for up to 0.5 seconds. The current will then reduce quickly as the motor reaches rated rotational speed. Within 5 minutes, as the oil and pump warms up, the current drawn will slowly reduce to a maximum of the full load current specified in [Table 11](#).

When you start a warm pump, the motor will draw the start-up current shown in [Table 11](#) for up to 0.5 seconds. The current drawn will then immediately fall to a maximum of the full load current.

Electrical short-circuit and ground-fault protection of the pump will be provided by fitting Class CC fuses of the values shown in [Table 11](#) at the point of connection to the supply. If these are not available in your country of use, Type aM European fuses of the same rating can also be used.

Table 11 - Electrical data (three-phase pumps with Item Numbers -905)

Pump	Nominal supply (V)	Frequency (Hz)	Power (W)	Full load current (A)	Start-up current (A)	Maximum fuse rating (A)
RV3 and RV5	220–240	50	250	1.7	10.2	2.5
	200–230	60	300	1.7	10.2	2.5
	380–415	50	250	1.0	5.7	2.5
	460	60	300	1.0	7.0	2.5
RV8 and RV12	220–240	50	450	2.5	14.0	4.0
	200–230	60	550	2.9	12.0	4.0
	380–415	50	450	1.5	9.0	2.5
	460	60	550	1.5	8.7	2.5

This page has been intentionally left blank.

3 Installation

3.1 Safety



WARNING

We recommend that you do not use a hydrocarbon-prepared RV pump for pumping hazardous substances. PFPE-prepared pumps are suitable for oxygen applications: refer to [Section 8](#).

You must ensure that the RV pump is suitable for your application. If you have any doubt as to the suitability of the RV pump for your application, refer to the Edwards guidelines on vacuum pump and vacuum system safety (see the Associated publications at the end of the Contents list at the front of this manual).

A suitably trained and supervised technician must install your RV pump. Obey the safety instructions listed below when you install the pump, especially when you connect the pump into an existing system. Details of specific safety precautions are given at the appropriate point in the instructions.

- Wear the appropriate safety-clothing when you come into contact with contaminated components.
- Vent and purge your vacuum system before you start installation work.
- Ensure that the installation technician is familiar with the safety procedures which relate to the pump-oil and the products handled by the pumping system. Take suitable precautions to avoid the inhalation of oil mist and excessive skin contact with pump-oil, as prolonged exposure can be harmful.
- Disconnect the other components in the pumping system from the electrical supply so that they cannot be operated accidentally.

3.2 System design considerations

Consider the following points when you design your pumping system:

- Use a suitable valve to isolate the pump from your vacuum system if you need to allow the pump to warm up before you pump condensable vapours, or to provide additional system protection when the pump is switched off.
- Avoid high levels of heat input to the pump from the process gases, otherwise the pump may overheat and seize, and cause the motor thermal overload device to open.
- If you use the pump in a high ambient temperature and have a high gas throughput, the temperature of the pump-body may exceed 70°C and you must fit suitable guards to prevent contact with hot surfaces.
- Make sure that the exhaust pipeline cannot become blocked. If you have an exhaust-isolation valve, make sure that you cannot operate the pump with the valve closed.
- Provide for a purge of inert gas when you shut down the pumping system, to dilute dangerous gases to safe concentrations. A suitable gas ballast adaptor for introduction of purge gas into the pump is available as an accessory (see [Section 7.4.8](#)).

3.3 Unpack and inspect

1. Remove all packing materials, and remove the pump from its packing-box.
2. Remove the protective covers from the inlet and outlet-ports and inspect the pump. If the pump is damaged, notify your supplier and the carrier in writing within three days; state the Item Number of the pump together with your order number and your supplier's invoice number. Retain all the packing materials for inspection. Do not use the pump if it is damaged.

If the pump is not to be used immediately, replace the protective covers. Store the pump in suitable conditions, as described in [Section 6.1](#).

3.4 Locate the pump



WARNING

Use suitable lifting equipment to move the RV8 or RV12 pump. The mass of the RV8 and RV12 pumps is approximately 26 kg.

The RV3 and RV5 pumps have a lifting handle which you can use to move the pump by hand. If you wish to use mechanical lifting equipment, do not attach the equipment to the handle; for stability, use slings around the motor and the pump-body.

Do not lift the RV8 and RV12 pumps by hand; attach your mechanical lifting equipment to the lifting bracket on the pump. You do not need to use slings to move the RV8 and RV12 pumps.

Provide a firm, level platform for the pump. Locate the pump so that the oil-level sight-glass is visible and the oil filler-plug, oil drain-plug, mode selector and gas-ballast control are accessible.

If your pump will be located inside an enclosure, make sure that there is adequate ventilation at both ends of the pump, so that the ambient temperature around the pump does not exceed 40°C. There must be a minimum space of 25 mm between the pump and the enclosure walls.

3.5 Fill the pump with oil



WARNING

You must not use a hydrocarbon-prepared pump to process oxygen in concentrations greater than 25 % in volume. If you do, there is a risk of fire or explosion in the oil-box of the pump. PFPE-prepared pumps are available: refer to [Section 8](#).

Fill the pump with oil as described below. Refer to [Section 2.5](#) for the recommended oil. Refer to [Figure 1](#) for the item numbers in brackets.

1. Remove one of the oil filler-plugs (6).
2. Pour oil into the pump until the oil-level just reaches the MAX mark on the bezel at the top of the sight-glass (8). If the oil-level goes above the MAX mark, remove the drain-plug (9) and drain the excess oil from the pump.
3. After a few minutes, recheck the oil-level. If the oil-level is now below the MAX mark, pour more oil into the pump.
4. Refit the oil filler-plug. Tighten the plug firmly by hand. Do not overtighten.

3.6 Fit the motor (bareshaft pumps only)

If you have a bareshaft pump, fit the motor to the pump now: refer to [Section 9](#).

3.7 Electrical installation: single-phase pumps

3.7.1 Check and configure the motor

CAUTION

Ensure that the motor is correctly configured for your electrical supply. If you operate the pump when the motor is not correctly configured for the electrical supply, you will damage the motor.

Refer to [Figure 4](#) for the item numbers in brackets.

Ensure that the voltage shown on the voltage indicator (4) in the motor-cover corresponds with your electrical supply voltage. If it does not, you must change the configuration of the pump-motor to match your electrical supply voltage; use the procedure below.

1. Undo the two retaining screws (6) securing the voltage selection switch cover (5).
2. Remove the voltage selection switch cover (5) and toggle the voltage selection switch (4) into the alternate position.
3. Invert the voltage selection switch cover (5) and refit over the voltage selection switch (4).
4. Refit the two retaining screws (6).

3.7.2 Connect the pump to your electrical supply

WARNING



Ensure that the electrical installation of the RV pump conforms with your local and national safety requirements. It must be connected to a suitably fused and protected electrical supply and a suitable earth (ground) point.

Notes: *In the UK, if you use a 13 A plug, it must comply with BS1363A and be fitted with a 13 A fuse which complies with BS1362.*

To prevent automatic restart of the pump-motor if the electrical supply is restored after an electrical supply failure, connect the pump to the electrical supply through suitable control equipment which must be reset manually after an electrical supply failure.

Make the electrical connections to the pump-motor with an IEC 320 cable socket (cold condition type) that satisfies your local electrical standards.

To maintain compliance with CSA standards, you must only use CSA/ UL certified electrical supply cables and connectors. Cables must be SJT rated (minimum) and must incorporate an earth conductor. The conductors in the cable must be a minimum of 18 AWG. The temperature rating of the cable must be 70°C or greater.

If your RV pump was supplied with an electrical supply cable, the cable will be fitted with a moulded IEC connector at one end. The other end of the cable may be fitted with a plug suitable for your local electrical supply. A cable without a plug will contain wires colour coded as follows:

Colour	Use
Green and yellow	Earth (ground)
Blue	Neutral
Brown	Live

1. Ensure that the on/ off switch on the motor (Figure 4, item 5) is in the 'off' position.
2. Insert the moulded IEC connector at the end of the cable into the electrical inlet-connector on the motor (Figure 4, item 2).
3. Connect the plug (if fitted) at the other end of the cable to your electrical supply. If a plug is not fitted, connect the wires in the cable to the correct terminals of your electrical supply.

3.7.3 Check the direction of rotation

CAUTION

Ensure that the pump-motor rotates in the correct direction. If it does not, the pump and your vacuum system can become pressurised.

Refer to Figure 1 for the item numbers in brackets.

1. Watch the motor cooling-fan through the motor fan-cover (13).
2. Use the on/ off switch (12) to switch-on the electrical supply to the motor for a few seconds.
3. Check that the motor cooling-fan rotates in the correct direction (14) shown by the arrow on the motor fan-cover. If the direction of rotation is incorrect, switch off the electrical supply immediately and contact your supplier or Edwards for advice.

Figure 4 - Motor voltage configuration: single-phase pumps

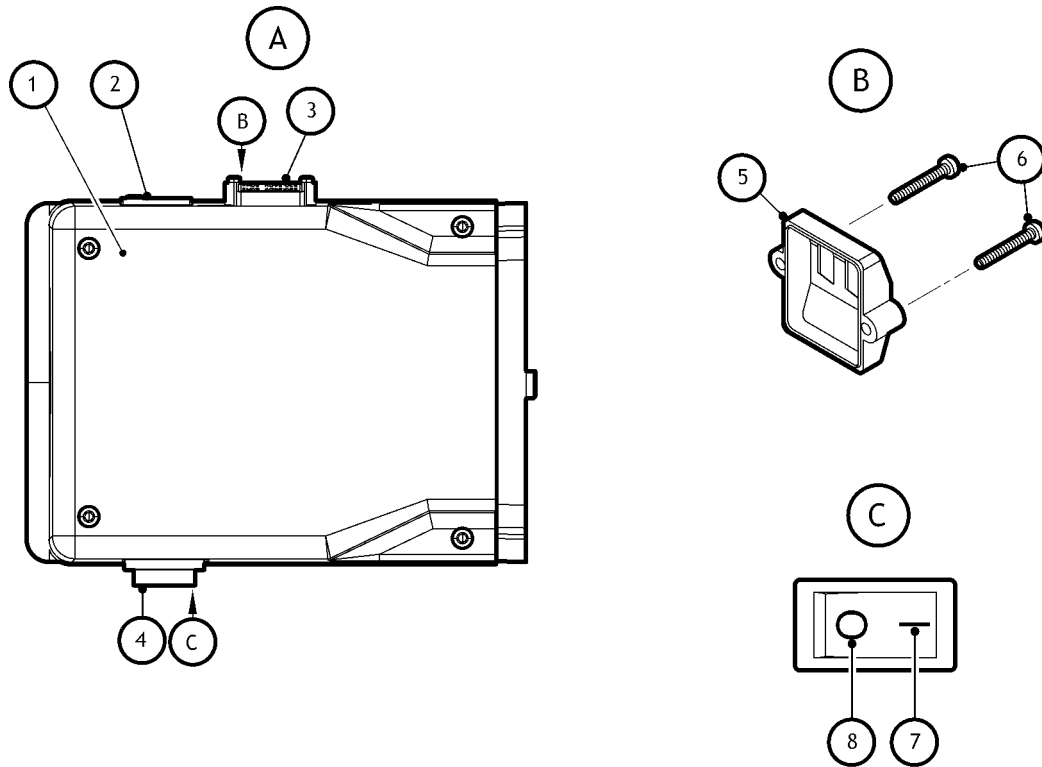

- A. Top view of motor
- B. View of voltage selector switch cover
- C. View of On-off switch

- 1. Terminal box
- 2. Electrical inlet-connector
- 3. Voltage selector switch
- 4. On-off switch
- 5. Voltage selector switch cover
- 6. Retaining screws
- 7. Position 'I' (on)
- 8. Position 'O' (off)

3.8 Electrical installation: three-phase pumps

3.8.1 Check and configure the motor

CAUTION

Ensure that the motor is correctly configured for your electrical supply. If you operate the pump when the motor is not correctly configured for the electrical supply, you will damage the motor.

1. Remove the screws which secure the cover of the motor terminal-box. Remove the cover.
2. Remove the cable-gland from the inside of the terminal-box and fit the cable-gland to the cable leadthrough hole in the side of the terminal-box.
3. Ensure that the motor is correctly configured for your electrical supply. If necessary, reconfigure the links (Figure 5 and Figure 6, item 1) to suit your electrical supply:
 - For 200–230 V electrical supplies, the links must be configured as shown in Figure 5.
 - For 380–460 V electrical supplies, the links must be configured as shown in Figure 6.

3.8.2 Connect the pump to your electrical supply



WARNING

Ensure that the electrical installation of the RV pump conforms with your local and national safety requirements. It must be connected to a suitably fused and protected electrical supply and a suitable earth (ground) point.

Notes: To prevent automatic restart of the pump-motor if the electrical supply is restored after an electrical supply failure, connect the pump to the electrical supply through suitable control equipment which must be reset manually after an electrical supply failure.

To maintain compliance with CSA (Canadian Standards Association) standards, you must incorporate a switch or circuit breaker in the pump electrical supply. The switch or circuit breaker must be close to the pump and easily accessible, and must be clearly marked to identify that it is the electrical supply disconnection device for the pump.

We recommend that you connect the electrical supply to the motor through a starter or circuit breaker which has thermal over-current protection which can be adjusted to suit the full load current ratings shown in Table 11. The fuse ratings in Table 11 are provided for guidance only. The supplier of your thermal over-current protection device may specify different values to ensure correct operation of the fuse and the over-current protection device. Ensure that the fuse you use is suitable for the starting currents given in Table 11.

1. Pass the electrical supply cable through the cable-gland. The diameter of the electrical supply cable should be in the range 7 to 11 mm.
2. Use insulated crimped connectors to connect the wires in the cable to the terminals U1, V1 and W1 and Earth (ground) in the terminal-box as shown in Figure 5 and Figure 6. You must tighten the earth (ground) terminal connection to a torque of 2.13 to 2.87 Nm.
3. Ensure that the cover gasket is correctly positioned, then refit the cover to the terminal-box and secure with the screws. Tighten the strain-relief nut on the cable-gland.

Figure 5 - Three-phase electrical connections: 200-230 V

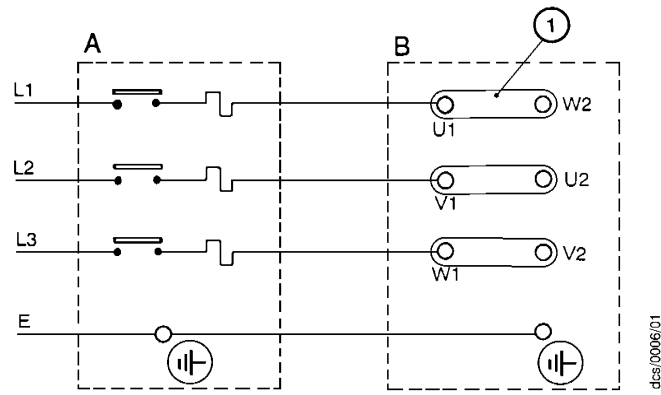

A. Starter/ contactor
B. Motor terminal-box

1. Links

Figure 6 - Three-phase electrical connections: 380-460 V

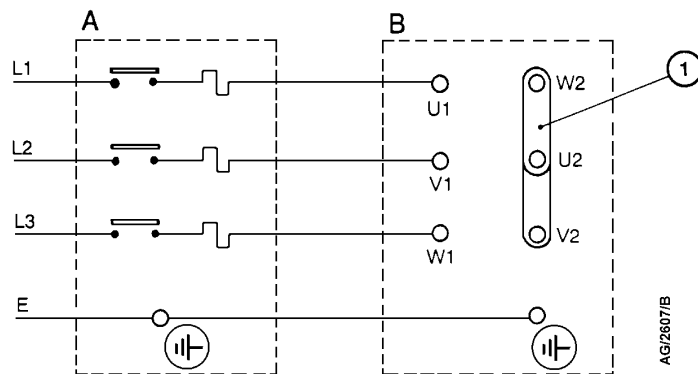

A. Starter/ contactor
B. Motor terminal-box

1. Links

3.8.3 Check the direction of rotation

CAUTION

Ensure that the pump-motor rotates in the correct direction. If it does not, the pump and your vacuum system can become pressurised.

1. Refer to [Figure 1](#). Watch the motor cooling-fan through the motor fan-cover (13).
2. Switch-on the electrical supply to the motor for a few seconds.
3. Check that the motor cooling-fan rotates in the correct direction shown by the arrow on the motor mounting plate. If the direction of rotation is incorrect:
 - Switch off the electrical supply immediately.
 - Isolate the pump from the electrical supply.
 - Remove the terminal-box cover and swap wires L1 and L3: see [Figure 5](#) and [Figure 6](#).
 - Refit the cover to the terminal-box.

3.9 Inlet and outlet connections



WARNING

Connect the exhaust to a suitable treatment plant to prevent the discharge of dangerous gases and vapours to the surrounding atmosphere. Use a catchpot to prevent the drainage of contaminated condensate back into the pump.

Before you connect the pump to your vacuum system, fit the centring-ring and inlet-filter (supplied with the pump) to the pump inlet-port (see [Figure 5](#)).

Take note of the following information when you connect the pump to your vacuum system. Refer to [Section 7.4](#) for details of the accessories mentioned below. Use standard NW25 fittings (not supplied) when you connect the pump.

- For optimum pumping speeds, ensure that the pipeline connected to the pump-inlet is as short as possible and has an internal diameter of 25 mm or larger.
- Support the vacuum pipelines to prevent loading of the coupling-joints.
- If necessary, incorporate flexible bellows in your system pipelines to reduce the transmission of vibration and to prevent loading of coupling-joints. If you use flexible bellows, you must ensure that you use bellows which have a maximum pressure rating which is greater than the highest pressure that can be generated in your system. We recommend that you use Edwards flexible bellows.
- Use a suitable inlet trap if you pump condensable vapours or if you use the pump for very dusty applications.
- Use a suitable valve to isolate the pump from your vacuum system if you need to pump condensable vapours or maintain vacuum when the pump is switched off.
- Ensure that sealing surfaces are clean and scratch-free.

In any of the following circumstances, we recommend that you fit an oil mist filter to the pump outlet:

- If you use the pump with the gas ballast control open (in position 'I' or position 'II').
- If you operate the pump with an inlet pressure greater than 10 mbar (1×10^3 Pa) for extended periods.
- If you frequently pump down from atmospheric pressure.

The oil mist filter will trap the oil exhausted from the pump; you can reuse the oil if it is not contaminated.

3.10 Leak-test the system

Leak-test the system and seal any leaks found after you have installed the RV pump, to prevent leakage of substances out of the system and leakage of air into the system.

This page has been intentionally left blank.

4 Operation



WARNING

Do not expose any part of your body to vacuum. If you do, you may be injured.

4.1 ATEX directive implications

4.1.1 Introduction

This equipment is designed to meet the requirements of Group II Category 3 equipment in accordance with Directive 94/9/EC of the European Parliament and the Council of 23rd March 1994 on the approximation of the laws of the Member States concerning equipment and protective systems intended for use in potentially explosive atmospheres. (The ATEX Directive)

The ATEX Category 3 applies in respect of potential ignition sources internal to the equipment. An ATEX Category has not been assigned in respect of potential ignition sources on the outside of the equipment as the equipment has not been designed for use where there is an external potentially explosive atmosphere.

There is no potential source of ignition within the pump during normal operation but there may be potential sources of ignition under conditions of predicted and rare malfunction as defined in the Directive. Accordingly, although the pump is designed to pump flammable materials and mixtures, operating procedures should ensure that under all normal and reasonably predicted conditions, these materials and mixtures are not within explosive limits. Category 3 is considered appropriate for the avoidance of ignition in the case of a rare malfunction which allows flammable materials or mixtures to pass through the pump while within their explosive limits.

4.1.2 Flammable/pyrophoric materials



WARNING

You must obey the instructions and take note of the precautions given below, to ensure that pumped gases do not enter their flammable ranges.

When flammable or pyrophoric materials are present within the equipment you must:

- Not allow air to enter the equipment.
- Ensure the system is leak tight.
- Use an inert gas purge (for example, a nitrogen purge) to dilute any flammable gases or vapours entering the pump inlet, and/ or use an inert gas purge to reduce the concentration of flammable gases or vapours in the pump and in the exhaust pipeline to less than one quarter of the gases' published lower explosive limits (LEL).
- Use an inert gas purge into the pump gas ballast connection to prevent the condensation of flammable vapours within the pump mechanism and exhaust pipeline.

4.1.3 Gas purges



WARNING

If you use inert gas purges to dilute dangerous gases to a safe level, ensure that the RV3, RV5, RV8 and RV12 rotary vane pump is shut down if an inert gas supply fails.



WARNING

You must obey the instructions and take note of the precautions given below, to ensure that pumped gases do not enter their flammable ranges.

Switch on the inert gas purge to remove air from the pump and the exhaust pipeline before the process starts. Switch off the purge flow at the end of the process only after any remaining flammable gases or vapours have been purged from the pump and exhaust pipeline.

If liquids that produce flammable vapours could be present in the pump foreline, then the inert gas purge to the RV3, RV5, RV8 and RV12 rotary vane pump should be left on all the time this liquid is present. Flammable liquids could be present in the foreline as a result of condensation, or may be carried over from the process.

When you calculate the flow rate of inert gas required for dilution, consider the maximum flow rate for the flammable gases/ vapours that could occur. For example, if a mass flow controller is used to supply flammable gases to the process, you should assume a flow rate for flammable gases that could arise if the mass flow controller is fully open.

Continually measure the inert gas purge flow rate: if the flow rate falls below that required, you must stop the flow of flammable gases or vapours into the pump.

Note: We recommend that you obtain and read the *Vacuum Pump and Vacuum System Safety manual* (publication number P300-20-000), available from Edwards or your supplier.

4.2 How to use the pump controls

4.2.1 Introduction

You can use the mode selector (Figure 1, item 11) and the gas-ballast control (Figure 1, item 5) to optimise the performance of the RV pump for your application. The performance characteristics of the pump with the different control settings are shown in Table 3 and Table 4. You can change the position of both the mode selector and the gas-ballast control when the pump is off or when the pump is operating.

4.2.2 Mode selector

Note: The pump is supplied with High Vacuum mode  selected. If High Vacuum mode is selected and you cannot turn the mode selector by hand to select the High Throughput mode, use a suitable tool fitted to the flat part of the mode selector to turn the selector.

The mode selector controls the flow of pressurised oil to the high vacuum stage of the pump (see [Section 1.4.1](#)). You can turn the mode selector to one of two positions, as follows:

To select the High Vacuum mode , turn the mode selector fully clockwise and tighten by hand. When High Vacuum mode is selected, there is a gap of approximately 3 mm between the mode selector and the inner face of the side panel of the pump. Use this mode:

- to achieve ultimate vacuum
- to pump clean gases
- to pump clean condensable vapours.

To select the High Throughput mode , turn the mode selector fully anticlockwise until it touches the inner face of the side panel of the pump, then gently tighten by hand. Use this mode:

- for long-term operation with high gas throughput (that is, inlet pressure > 50 mbar)
- to pump dirty condensable vapours
- to decontaminate the oil.

4.2.3 Gas-ballast control

Use the gas-ballast control to change the amount of air (or inert gas) introduced into the low vacuum stage of the pump (refer to [Section 1.4.2](#)). Use of gas-ballast will prevent the condensation of vapours in the pump; the condensates would contaminate the oil. You can turn the gas-ballast control to select one of three positions, as follows:

To select gas-ballast closed, turn the control to position '0'. Use this setting:

- to achieve ultimate vacuum
- to pump dry gases.

To select low flow gas-ballast, turn the control to position 'I'. Use this setting:

- to pump low concentrations of condensable vapours
- to decontaminate the oil.

To select high flow gas-ballast, turn the control to position 'II'. Use this setting:

- to pump high concentrations of condensable vapours.

When you use either low flow or high flow gas-ballast, there will be an increased rate of oil loss from the pump. Where possible, we recommend that you select low flow gas-ballast (position 'I') rather than high flow gas-ballast (position 'II') to minimise the loss of oil.



4.3 Start-up procedure



WARNING

Ensure that your system design does not allow the exhaust pipeline to be blocked.

If the oil is contaminated, or if the pump temperature is below 12°C, or if the electrical supply voltage is more than 10% below the lowest voltage specified on the voltage indicator (Figure 4, item 4), the pump may operate at a reduced speed for a few minutes. On single-phase pumps, if the pump continues to operate at reduced speed, the motor thermal overload device will open and stop the pump. When the motor has cooled, the thermal overload device will reset automatically and the pump will restart.



1. Check that the pump oil-level is between the MAX and MIN marks on the bezel of the oil-level sight-glass; if it is not, refer to Section 5.3.
2. Turn the mode selector fully clockwise to select High Vacuum mode  or fully anticlockwise to select High Throughput mode , as required (refer to Section 4.2.2).
3. Turn the gas-ballast control to position '0', 'I' or 'II', as required (refer to Section 4.2.3).
4. Switch on the electrical supply to the pump; on single-phase pumps, use the on/ off switch.
5. If you want to achieve ultimate vacuum, to pump condensable vapours or to decontaminate the pump oil, refer to the procedures in Section 4.4, 4.5 and 4.6 respectively. Otherwise, open the vacuum system isolation-valve.

4.4 To achieve ultimate vacuum

If the pump does not achieve the performance specified in Section 2.2, make sure that this is not due to your system design before you contact your supplier or Edwards for advice. In particular, the vapour pressure of all materials used in your vacuum system (including pump oil, see below) must be much lower than the specified ultimate vacuum of the pump. Refer to Section 5.12.3 for a list of possible causes for failure to achieve the specified performance; note however that the most common causes are:

- Your pressure measurement technique or gauge head is unsuitable or the gauge head is faulty.
- You have used an oil other than the recommended oil, and the vapour pressure of the oil is higher than the specified ultimate vacuum of the pump.



Use the following procedure to achieve ultimate vacuum:

1. Isolate the RV pump from your vacuum system.
2. Turn the mode selector to select High Throughput mode , set the gas-ballast control to low flow (position 'I') and operate the pump for at least 1 hour (or overnight) to thoroughly purge the oil of contaminants.
3. Turn the mode selector to select High Vacuum mode  and close the gas-ballast control (that is, set it to position '0').

Open the vacuum system isolation-valve and pump down to ultimate vacuum.

4.5 To pump condensable vapours

Use gas-ballast (gas-ballast control in position 'I' or 'II') when there is a high proportion of condensable vapours in the process gases.

1. Close the vacuum system isolation-valve.
2. Turn the mode selector fully clockwise to select High Vacuum mode  or fully anticlockwise to select High Throughput mode , as required (refer to [Section 4.2.2](#)).
3. Turn the gas-ballast control to high flow (position 'II') and operate the pump for 30 minutes to warm the oil; this will help to prevent vapour condensation in the pump.
4. Set the gas-ballast control to the position required for your application (refer to [Section 4.2.3](#) and the data in [Table 3](#) and [Table 4](#)).
5. Open the vacuum system isolation-valve.

After you have pumped condensable vapours, you can (if necessary) decontaminate the oil: use the procedure in [Section 4.6](#).

4.6 To decontaminate the oil

The oil in the pump should be clear; if the oil is cloudy or discoloured, it is contaminated with process vapours.

1. Look at the condition of the oil in the oil-level sight-glass ([Figure 1](#), item 8). If the oil is cloudy or discoloured, continue with the procedure at [Step 2](#) below.
2. Close the vacuum system isolation-valve.
3. Turn the mode selector fully anticlockwise to select High Throughput mode . Set the gas-ballast control to low flow (position 'I').
4. Operate the pump until the oil is clear.

4.7 Unattended operation

The RV pump is designed for unattended operation under the normal operating conditions specified in [Section 2.1](#). However, we recommend that you check the pump at regular intervals of not more than 14 days, or more frequently if you pump high volumes of gas or vapour.

On single-phase pumps, the motor is protected by an overload device which isolates the pump from the electrical supply when critical temperature or current levels are exceeded. The overload device resets automatically when the motor has cooled. When you check the pump, make sure that the pump is not going through a repetitive cycle of thermal overload failures and automatic resets. If necessary, change the mode selector to High Throughput mode  and reduce the thermal load from the pumped gases, to prevent overheating of the pump.

4.8 Shut-down

We recommend, as described in the procedure below, that you decontaminate the oil before you shut down the pump; this will prevent damage to the pump by the contaminants in the oil.

1. Refer to [Section 4.6](#) and decontaminate the oil, as required.
2. Close the vacuum system isolation-valve (if not already closed).
3. Close gas-ballast (that is, set the gas-ballast control to position '0').
4. On single-phase pumps, use the on/ off switch to switch off the pump.
5. Switch off the electrical supply to the pump.

5 Maintenance

5.1 Safety information



WARNING

Obey the safety instructions given below and take note of appropriate precautions. If you do not, you can cause injury to people and damage to equipment.

- If your pump is PFPE-prepared, refer to [Section 8](#) before you maintain the pump.
- A suitably trained and supervised technician must maintain the pump. Obey your local and national safety requirements.
- Ensure that the maintenance technician is familiar with the safety procedures which relate to the pump-oil and the products processed by the pumping system.
- Check that all the required parts are available and of the correct type before you start work.
- Isolate the pump and other components from the electrical supply so that they cannot be operated accidentally.
- Allow the pump to cool (so that it is at a safe temperature for skin contact) before you start maintenance work. Make sure the pump is switched off in case the thermal overload device restarts the pump.
- Do not reuse O-rings and seals if they are damaged.
- After maintenance is completed, recheck the direction of pump rotation if the electrical supply has been disconnected.
- The pump and the pump-oil will be contaminated with the process chemicals that have been pumped during operation. Ensure that the pump is decontaminated before maintenance and that you take adequate precautions to protect people from the effects of dangerous substances if contamination has occurred.
- Do not touch or inhale the thermal breakdown products of fluorinated materials which may be present if the pump has been heated to 310° C and above. Fluorinated materials are safe in normal use but can decompose into very dangerous substances (which may include hydrofluoric acid) if they are heated to 310° C and above. The pump may have overheated if it was misused, if it malfunctioned, or if it was in a fire. Material Safety Data Sheets for fluorinated materials used in the pump are available on request: contact your supplier or Edwards.
- If necessary, maintain the motor as specified in the manufacturers information supplied with the motor.

5.2 Maintenance plan

The plan shown in [Table 12](#) details the routine maintenance operations necessary to maintain RV pumps in normal use. Instructions for each operation are given in the section shown.

More frequent maintenance may be required if the pump is used to pump corrosive or abrasive gases and vapours, such as solvents, organic substances and acids; in these circumstances, we recommend that you replace the pump seals every year (refer to [Section 7.3](#) for details of available spares). If necessary, adjust the maintenance plan according to your experience.

When you maintain the RV pump, use Edwards spares and maintenance kits; these contain all of the components necessary to complete maintenance operations successfully. The Item Numbers of the spares and kits are given in [Section 7.3](#).

Table 12 - Maintenance plan

Operation	Frequency	Refer to Section
Check the oil-level	Monthly	5.3
Replace the oil	Every 3000 hours of operation	5.4
Inspect and clean the inlet-filter	Yearly	5.5
Inspect and clean the gas-ballast control	Yearly	5.6
Clean the oil-level sight-glass	Yearly	5.7
Clean the motor fan-cover and enclosure	Yearly	5.8
Clean and overhaul the pump	Every 15000 hours of operation	5.9
Fit new blades	Every 30000 hours of operation	5.10
Test the motor condition	Every 15000 hours of operation	5.11

5.3 Check the oil-level

Note: *If required, you can check the oil-level while the pump is operating, however you must switch off the pump and isolate the pump and other components in the pumping system from the electrical supply before you pour oil into the pump.*

Refer to [Figure 1](#) for the items in brackets.

1. Check that the oil-level in the sight-glass (8) is between the MAX and MIN level marks on the bezel of the sight-glass.
2. If the oil-level is near to or below the MIN level mark, remove one of the filler-plugs (6) and pour more oil into the reservoir until the oil reaches the MAX level mark. If the oil-level goes above the MAX mark, remove the drain-plug (9) and drain the excess oil from the pump. Refit the filler-plug.
3. If the oil is contaminated, drain and refill the pump with clean oil as described in [Section 5.4](#).

5.4 Replace the oil

1. Refer to [Figure 1](#). Operate the pump for approximately ten minutes to warm the oil, then switch off the pump (this lowers the viscosity of the oil and enables it to be drained from the pump more easily).
2. Isolate the pump from your electrical supply and disconnect it from your vacuum system.
3. Remove one of the oil filler-plugs (6).
4. Place a suitable block under the pump-motor to tilt the pump and place a suitable container under the drain-plug (9). Remove the drain-plug and allow the oil to drain into the container.
5. If the oil drained from the pump is contaminated, pour clean oil into the filler-hole and allow it to drain out of the pump. Repeat this step until the oil reservoir in the pump has been thoroughly cleaned.
6. Refit the drain-plug, remove the block and reconnect the pump to your vacuum system.
7. Fill a suitable container with clean oil and pour the oil into the filler hole until the oil-level reaches the MAX level mark on the bezel of the sight-glass (8).
8. Allow a few minutes for the oil to drain into the pump. If necessary, add more oil. Refit the filler-plug.

5.5 Inspect and clean the inlet-filter

1. Refer to [Figure 7](#). Disconnect your vacuum system from the pump inlet-port (3) and remove the centring-ring and filter assembly (1) and the O-ring (2). Inspect the centring-ring and the O-ring. If they are clean, continue at Step 5. If they are not clean, continue at Step 2.
2. Remove the O-ring (2) from the centring-ring and filter assembly (1). Do not allow the O-ring to come into contact with the cleaning solution.
3. Wash the centring-ring and filter assembly in a suitable cleaning solution and allow it to dry.
4. If necessary, wipe the O-ring with a clean, dry, lint-free cloth.
5. Refit the centring-ring and filter assembly and the O-ring to the inlet-port. Refit your vacuum system to the pump inlet-port.

Figure 7 - Inlet-filter assembly

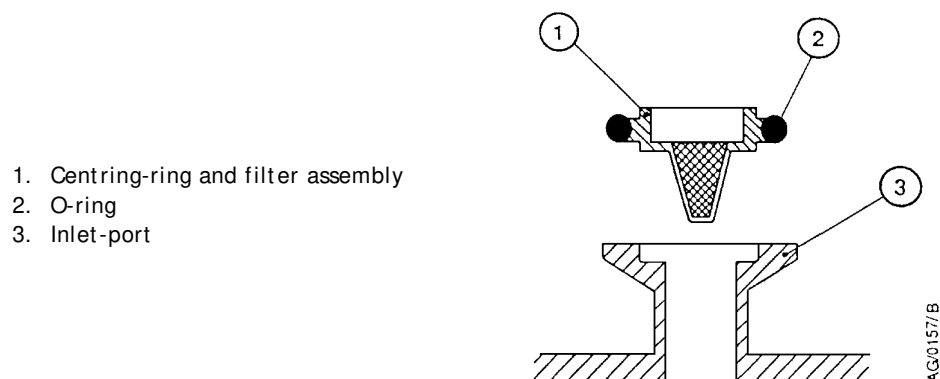

1. Centring-ring and filter assembly
2. O-ring
3. Inlet-port

AG0157/B

5.6 Inspect and clean the gas-ballast control

Note: The gas-ballast filter element (Figure 8, item 7) is retained in its seating with adhesive; do not try to remove it.

1. Refer to Figure 8. Turn the gas-ballast control (1) to the high flow position (position 'II').
2. Push the control down against the compression spring (6) as far as it will go, then turn the control anticlockwise slightly to release the bayonet-lugs (5) and remove the control.
3. If necessary, wipe the control with a clean, dry, lint-free cloth and check that the air-hole (3) is not blocked.
4. Refit the control into the gas-ballast inlet and ensure that the compression spring locates correctly between the bayonet-lugs.
5. Push the control down as far as it will go and then turn the control clockwise slightly until the bayonet-lugs engage correctly.
6. Reset the gas-ballast control to the required position.

Figure 8 - Gas-ballast control assembly

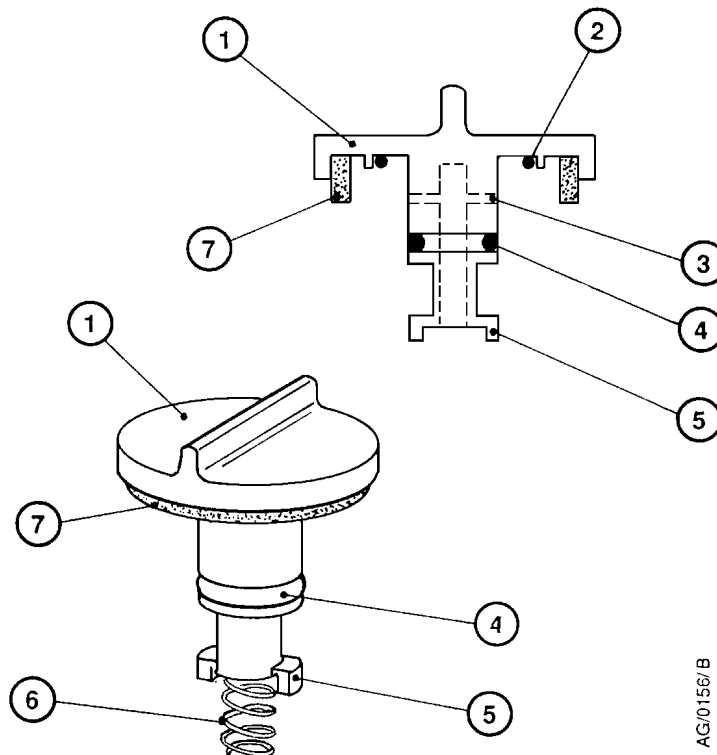

AG/0156/B

1. Gas-ballast control
2. O-ring
3. Air-hole
4. O-ring
5. Bayonet-lugs
6. Compression spring
7. Filter element

5.7 Clean the oil-level sight-glass

Refer to [Figure 9](#) for the item numbers in brackets.

1. Drain the oil as described in [Section 5.4](#).
2. Undo the two screws (1) and remove the bezel (2), the sight-glass (3) and the O-ring (4) from the oil-box (5).
3. Clean the screws, bezel and sight-glass with a suitable cleaning solution.
4. Wipe the O-ring with a clean, dry, lint-free cloth.
5. Wipe the sight-glass recess in the oil-box with the cloth.
6. Refit the O-ring, sight-glass and bezel and secure with the two screws.
7. Refill the pump with oil as described in [Section 5.4](#).
8. Check that the sight-glass does not leak.

Figure 9 - Sight-glass assembly

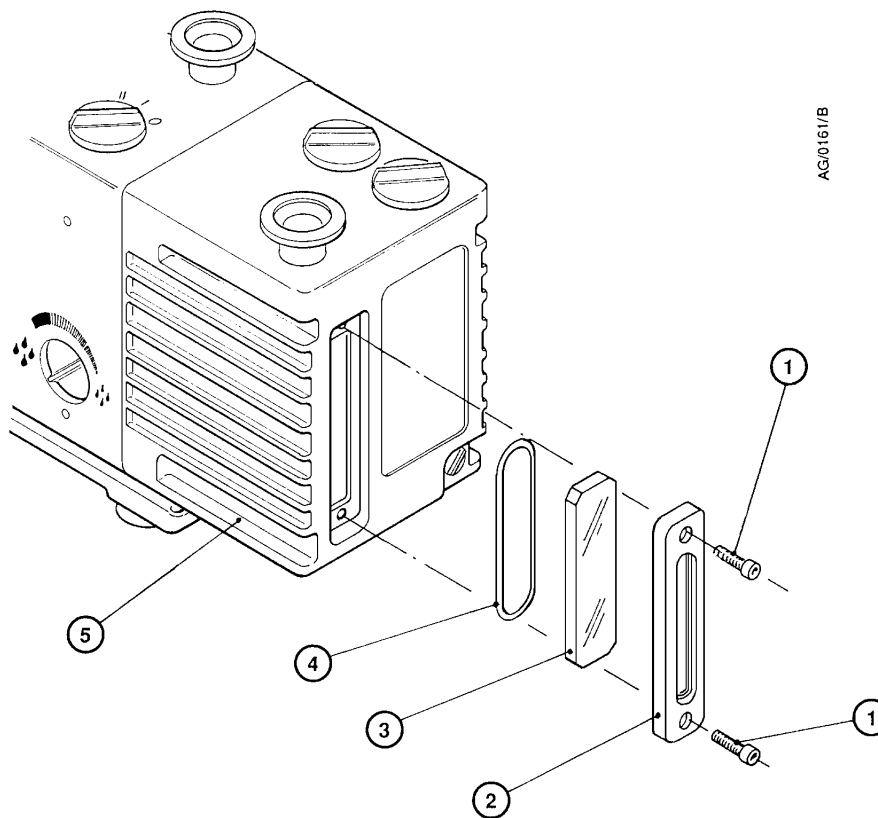

1. Screws (2 off M6 x 20)
2. Bezel
3. Sight-glass
4. O-ring
5. Oil-box

5.8 Clean the motor fan-cover and enclosure

If the motor fan-cover and enclosure are not kept clean, the air-flow over the motor can be restricted and the pump may overheat.

1. Switch off the pump and disconnect it from the electrical supply.
2. Use a dry cloth and a soft brush to remove dirt and deposits from the fan-cover and enclosure.

5.9 Clean and overhaul the pump

Clean and overhaul the pump as described in the instructions supplied with the clean and overhaul kit (see Section 7.3).

5.10 Fit new blades

Fit new blades to the pump as described in the instructions supplied with the blade kit (see Section 7.3).

5.11 Test the motor condition

Test the earth (ground) continuity and the insulation resistance of the pump-motor, in accordance with local regulations for periodic testing of electrical equipment.

The motor of single-phase RV pumps complies with IEC 1010-1. We recommend that, to maintain compliance with IEC 1010-1, the earth continuity is less than 0.1 Ω and the insulation resistance is greater than 10 M Ω .

If the motor fails these tests, you must replace the motor.

5.12 Fault-finding

5.12.1 Introduction

A list of fault conditions and their possible causes is provided in the following sections to assist you in fault-finding. If you are unable to rectify a fault when you use this guide, call your nearest Edwards Service Centre for help.

5.12.2 The pump has failed to start

- The electrical supply fuse has failed
- The electrical supply voltage does not match that of the motor
- The outlet pipeline or the outlet-filter (if fitted) is blocked
- The oil temperature is below 12° C
- The oil is too viscous
- The oil is contaminated
- The pump has seized after long storage
- The pump has been left to stand after contaminants have been pumped and has seized
- The motor is faulty.

5.12.3 The pump has failed to achieve the specified performance (has failed to reach ultimate vacuum)

- Your pressure measurement technique or gauge head is unsuitable or gives an incorrect indication of pressure. For example, a contaminated Pirani gauge can indicate a pressure which is several times higher than the actual pressure in the system.
- You have filled the pump with the wrong type of oil
- There is a leak in your vacuum system
- The mode selector and gas-ballast control are set incorrectly
- The oil-level is below minimum level
- The oil is contaminated
- Your vacuum fittings are dirty or damaged
- The inlet-filter is blocked
- The pump has not warmed up.

5.12.4 The pump is noisy

- The motor fan-cover is damaged
- The motor bearings are worn
- The oil is contaminated with solid particles.

5.12.5 The pump surface temperature is above 100° C

Note: *If the inlet pressure is continuously higher than 100 mbar (1×10^4 Pa), the surface temperature of the RV12 pump can reach 115°C when the ambient temperature is 40°C.*

- The ambient temperature is too high
- The cooling-air supply is insufficient or is too hot
- The electrical supply voltage is too high
- The outlet-filter or the outlet pipeline is blocked
- The oil-level is below minimum level
- You have filled the pump with the wrong type of oil
- The oil is contaminated
- The process gas is too hot or the throughput is too high.

5.12.6 The vacuum is not fully maintained after the pump is switched off

- The gas-ballast control is open (that is, in position 'I' or 'II')
- The inlet valve-pad is damaged
- The inlet valve has not closed.

5.12.7 The pumping speed is poor

- The connecting pipelines are too small in diameter
- The connecting pipelines are too long
- The inlet-filter is blocked.

5.12.8 There is an external oil leak

- The outer shaft-seal is worn or damaged
- The oil-box gaskets have deteriorated
- There is an oil leak from the gas-ballast control
- There is an oil leak from the drain-plug
- There is an oil leak from the sight-glass

6 Storage and disposal

6.1 Storage

CAUTION

Observe the storage temperature limits stated in [Section 2.1](#). Storage below -30°C will permanently damage the pump seals.

Note: If you will store a new pump in conditions of high humidity, remove the pump from its cardboard packaging box; dispose of the box (refer to [Section 6.2](#)).

Use the following procedure to store the pump:

1. Shut-down the pump as described in [Section 4.8](#).
2. Disconnect the pump from the electrical supply.
3. Purge your vacuum system and the pump with dry nitrogen and disconnect the pump from your vacuum system.
4. Replace the oil as described in [Section 5.4](#).
5. Place and secure protective covers over the inlet and outlet-ports.
6. Store the pump in cool, dry conditions until required for use. When required, prepare and install the pump as described in [Section 3](#). If the pump has been stored for more than a year, before you install the pump you must clean and overhaul it as described in the instructions supplied with the clean and overhaul kit.

6.2 Disposal

Dispose of the pump and any components removed from it safely in accordance with all local and national safety and environmental requirements.

Take particular care with components and waste oil which have been contaminated with dangerous process substances.

Do not incinerate fluoroelastomer seals and O-rings.

This page has been intentionally left blank.

7 Service and spares

7.1 Introduction

Edwards products, spares and accessories are available from Edwards companies in Belgium, Brazil, China, France, Germany, Israel, Italy, Japan, Korea, Singapore, United Kingdom, U.S.A and a world-wide network of distributors. The majority of these centres employ Service Engineers who have undergone comprehensive Edwards training courses.

Order spare parts and accessories from your nearest Edwards company or distributor. When you order, state for each part required:

- Model and Item Number of your equipment
- Serial number
- Item Number and description of part.

7.2 Service

Edwards products are supported by a world-wide network of Edwards Service Centres. Each Service Centre offers a wide range of options including: equipment decontamination; service exchange; repair; rebuild and testing to factory specifications. Equipment which has been serviced, repaired or rebuilt is returned with a full warranty.

Your local Service Centre can also provide Edwards engineers to support on-site maintenance, service or repair of your equipment.

For more information about service options, contact your nearest Service Centre or other Edwards company.

7.3 Spares

See [Table 13](#) for the spares and maintenance kits available for the RV pumps.

As of the end of 2009 improved motors have been fitted to RV pumps. These motors benefit from being fitted with an aluminium terminal box and externally accessible voltage change over switches. The introduction of these motors has resulted in the range of motors covering all voltage and frequency conditions being reduced from four variants to two. All motors are interchangeable and pump performance is not affected.

Table 13 - Spares and maintenance kits

Spare	Item Numbers	
	Hydrocarbon-prepared pumps	PFPE-prepared pumps
Ultragrade 19 oil, 1 litre	H110-25-015	–
Ultragrade 19 oil, 4 litres	H110-25-013	–
Fomblin 06/ 6 oil, 1 kg	–	H113-06-019
Fomblin 06/ 6 oil, 5 kg	–	H113-06-020
Clean and overhaul kit (Standard)	A652-01-131	A652-01-131
RV3 Blade kit	A652-01-130	A652-01-130
RV5 Blade kit	A653-01-130	A653-01-130
RV8 Blade kit	A654-01-130	A654-01-130
RV12 Blade kit	A655-01-130	A655-01-130
RV3 Cartridge Kit	A652-01-032	A652-09-032
RV5 Cartridge Kit	A653-01-032	A653-09-032
RV8 Cartridge Kit	A654-01-032	A654-09-032
RV12 Cartridge Kit	A655-01-032	A655-09-032
Inlet-valve kit	A652-01-036	A652-01-036
Motor Starting Relay Kit	A505-74-000	A505-74-000
Outer Shaft-Seal Kit	A652-01-134	A652-01-134
Rotor Sleeve Kit	A652-01-136	A652-09-136
Motor RV MT 450/ 550 W (Europe/ USA)	A652-99-010	A652-99-010
Motor RV MT 450/ 550 W (Japan)	A652-99-011	A652-99-011
RV3/ RV5 Motor Kit (Europe/ USA/ Japan) 50/ 60 Hz, 250/ 300 W, 3 phase, 200-230/ 380-460 V	A652-97-000	A652-97-000
RV8/ RV12 Motor Kit (Europe/ USA/ Japan) 50/ 60 Hz, 450/ 550 W, 3 phase, 200-230/ 380-460 V	A654-97-000	A654-97-000
Clean and Overhaul Kit (Nitrile)	A652-01-137	–

7.4 Accessories

7.4.1 Introduction

The accessories which can be fitted to the RV pump are shown in Figure 10, and their Item Numbers are listed in Table 14.

These accessories are briefly described in Section 7.4.2 to 7.4.14.

Table 14 - Accessory item numbers

Accessory	Refer to Section	Item Number
ITO20K Inlet catchpot	7.4.2	A441-10-000
ITF20K Inlet dust filter	7.4.3	A442-15-000
ITD20K Inlet desiccant trap	7.4.4	A445-10-000
ITC20K Inlet chemical trap	7.4.5	A444-10-000
FL20K Foreline trap	7.4.6	A133-05-000
EMF10 Outlet mist filter	7.4.7	A462-26-000
EMF20 Outlet mist filter	7.4.7	A462-29-000
Gas-ballast adaptor	7.4.8	A505-02-000
Gravity oil drain kit	7.4.9	A505-01-000
Oil drain-extension	7.4.10	A505-03-000
Exhaust nozzle kit	7.4.11	A505-09-000
Vibration isolators (pack of four)	7.4.12	A248-01-404
EBV20 Solenoid Operated Gas-Ballast Valve	7.4.13	
220-240 V 50/ 60 Hz		A500-06-930
100-120 V 50/ 60 Hz		A500-06-984
PV25EK Pipeline Valve (aluminium)	7.4.14	
220-240 V 50/ 60 Hz		C413-01-000
110-127 V 50/ 60 Hz		C413-03-000
PV25EK Pipeline Valve (stainless steel)	7.4.14	
220-240 V 50/ 60 Hz		C413-02-000
110-127 V 50/ 60 Hz		C413-04-000

7.4.2 Inlet catchpot

The inlet catchpot traps any liquid droplets and prevents their entry into the pump.

7.4.3 Inlet dust filter

The inlet dust filter protects the pump against abrasive dust.

7.4.4 Inlet desiccant trap

Use a desiccant trap when you pump limited quantities of water vapour at high pumping speeds to a low vapour pressure.

7.4.5 Inlet chemical trap

The inlet chemical trap protects the pump against chemically active gases.

7.4.6 Foreline trap

Use a foreline trap on a clean pumping system to prevent back-migration of pump-oil vapour into your vacuum system.

7.4.7 Outlet mist filter

The outlet mist filter separates and traps oil droplets in the pump outlet to prevent oil mist discharge.

7.4.8 Gas-ballast adaptor

Fit the gas-ballast adaptor in place of the gas-ballast control on the pump. The adaptor allows you to fit a solenoid operated gas-ballast valve or a controlled supply of inert gas to the pump.

7.4.9 Gravity oil drain kit

Fit the oil drain kit between the drain port of the outlet mist filter and the oil filler-plug on the pump. When the kit is fitted, oil will be returned from the mist filter to the pump when the pump is switched off or when the gas-ballast control is closed (in the '0' position) and there is no process gas being pumped.

7.4.10 Oil drain-extension

Fit the oil drain-extension between the oil drain port on the pump and the oil drain-plug to make the drainage of oil from the pump easier.

7.4.11 Exhaust nozzle kit

The exhaust nozzle replaces the outlet flange. Use the exhaust nozzle to connect the pump outlet to 12 mm internal diameter plastic hose.

7.4.12 Vibration isolators

Vibration isolators reduce vibration and noise when the pump is floor or frame mounted and help to reduce strain when the mounting area is uneven.

7.4.13 Solenoid operated gas-ballast valve

Fit the gas-ballast valve in place of the built-in gas-ballast control on the pump; you must fit the gas-ballast adaptor (see [Section 7.4.8](#)) with the solenoid operated gas-ballast valve. The valve provides automatic on/ off control of the gas-ballast and isolates the gas-ballast inlet when the pump is switched off.

7.4.14 Solenoid operated pipeline valve

Fit the pipeline valve between your vacuum system and the pump-inlet to provide additional system protection when the pump is switched off.

Figure 10 - Accessories

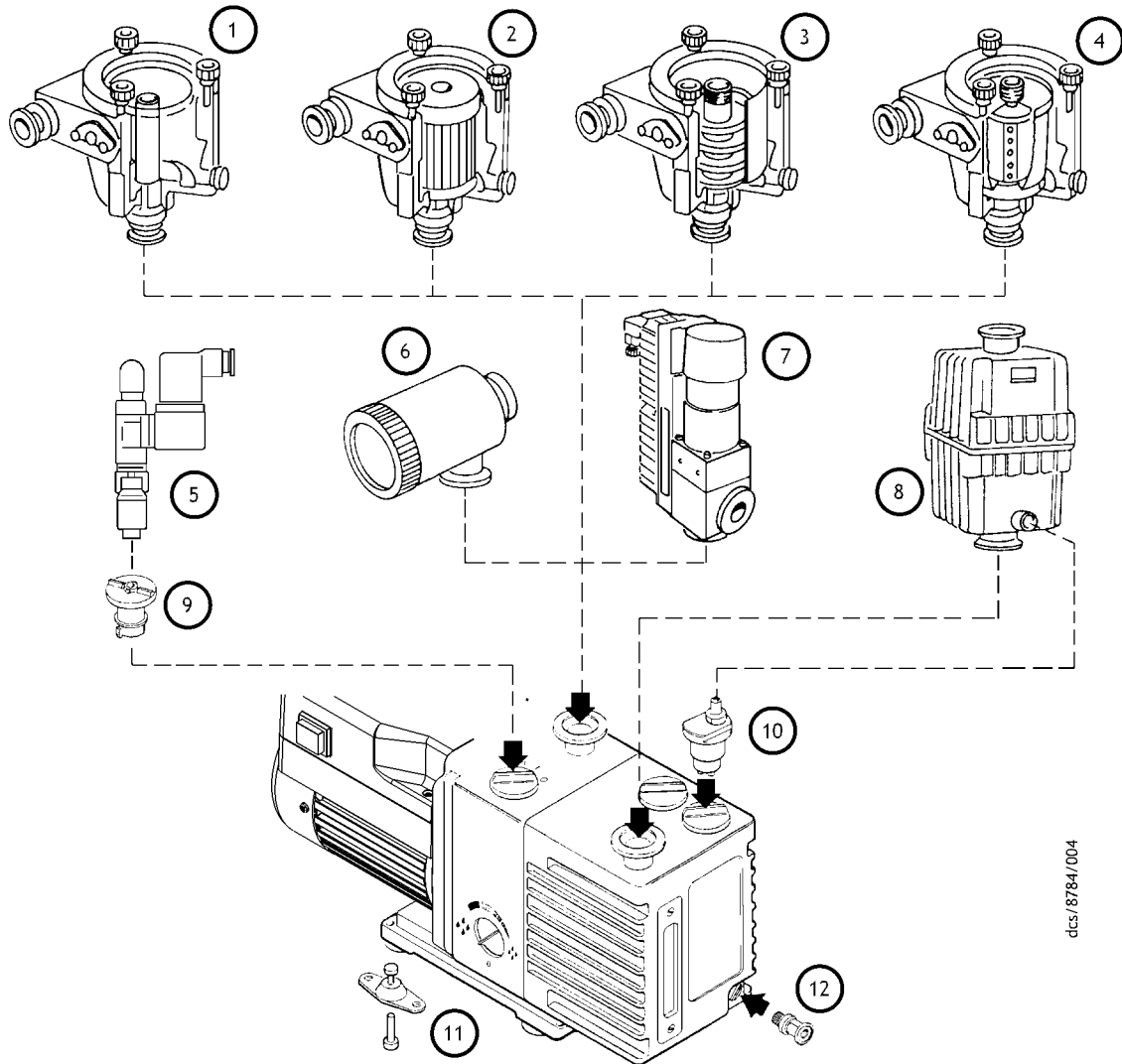

dcs/8784/004

- | | |
|--|---------------------------|
| 1. Inlet catchpot | 8. Outlet mist filter |
| 2. Inlet dust filter | 9. Gas-ballast adaptor |
| 3. Inlet desiccant trap | 10. Gravity oil drain kit |
| 4. Inlet chemical trap | 11. Vibration isolators |
| 5. Solenoid operated gas-ballast valve | 12. Oil drain-extension |
| 6. Foreline trap | |
| 7. Solenoid operated pipeline valve | |

This page has been intentionally left blank.

8 PFPE-prepared RV pumps

8.1 Summary

If you have ordered a PFPE-prepared RV pump, the pump will be supplied prepared for use with Edwards PFPE mechanical pump oils, such as Fomblin YVAC 06/ 6 and Krytox 1506.

PFPE-prepared RV pumps are suitable for pumping high concentrations of oxygen.

We recommend that you refer to Edwards publication P300-20-000 (Vacuum pump and Vacuum System Safety) before you install and use a PFPE-prepared RV pump.

8.2 Installation

CAUTION

Never use hydrocarbon lubricants in a PFPE-prepared pump.

When you fill the RV pump with oil (as described in [Section 3.5](#)), you must use a suitable Edwards PFPE oil. You must not use a hydrocarbon oil.

8.3 Operation



WARNING

PFPE-prepared RV pumps are suitable for pumping high concentrations of oxygen, but we recommend that you do not use a PFPE-prepared RV pump for the pumping of hazardous materials.

Operation of a PFPE-prepared RV pump is as specified in [Section 4](#), but take note of the warning above.

8.4 Maintenance



WARNING

Obey the safety instructions given below and take note of appropriate precautions. If you do not, you can cause injury to people.

- Take additional care if you suspect that the pump (and hence the PFPE oil) has overheated.
- Do not touch or inhale the thermal breakdown products of PFPE oil which may be present if the pump has been heated to 260°C and above. PFPE oils are safe in normal use but can decompose into very dangerous substances if they are heated to 260°C and above. The pump may have overheated if it was misused, if it malfunctioned, or if it was in a fire. Material Safety Data Sheets for PFPE oils used in the pump are available on request: contact your supplier or Edwards.

Fomblin oil has different properties from other pump oils, therefore:

- If you fill your PFPE-prepared RV pump with Fomblin oil, we recommend that you regularly check for oil leaks, particularly around the shaft seals.
- If you detect an oil leak, contact your supplier or Edwards for advice.

This page has been intentionally left blank.

9 Bareshaft RV pumps

9.1 Description

Two types of bareshaft pump are available:

- To suit an IEC72-1 motor with an (IMB14) FT85 face mounting and 14 mm diameter shaft.
- To suit a NEMA 56C motor with a $\frac{5}{8}$ inch diameter shaft.

The motor you will fit must have a power rating which is adequate for use with the RV pump: refer to the pump electrical data section in the manual.

Note: *The performance data given in Section 2 applies to pumps supplied with a motor fitted as standard. On a bareshaft pump, the performance may be affected by the type of motor fitted.*

9.2 Fit the motor to the bareshaft pump

1. Refer to [Figure 11](#). Use the four screws (455) to fit the motor support (453) to the motor.
2. Use the two screws (422) to fit the lifting plate (413), then fit the lifting plate cover (414).
3. Fit the fan ducting sheet (409).
4. Ensure that key 'B' is in place on the motor shaft, then push the fan (410) onto the shaft. Ensure that:
 - The end of the shaft aligns with the bottom of the cavity in the fan.
 - The back of the fan is 2.5 mm from the ducting sheet.
5. Secure the fan to the shaft with the screw (454): tighten the screw to a torque between 7 and 9 Nm.
6. Use a suitable lubricant on the coupling element (411) then fit the element to the coupling hub.
7. Align the coupling element in the hub with the coupling in the fan and fit the motor to the pump.
8. Secure the motor with the four screws (421). Tighten the screws to a torque of between 10 and 12 Nm. Note that:
 - The gap between the coupling faces must be 2 mm or less.
 - If necessary, adjust the position of the coupling hub on the pump shaft so that the gap is correct.

Figure 11 - Fit the motor to a bareshaft pump

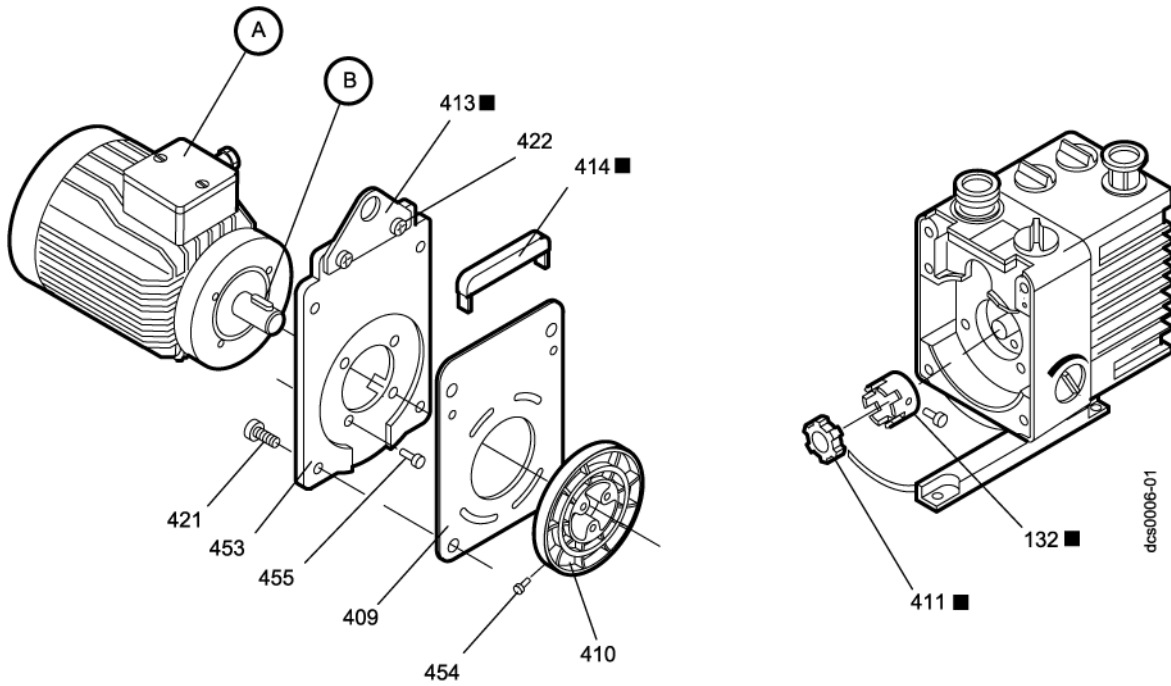

- A. Pump motor
- B. Key (in shaft)
- 132 Coupling hub
- 409 Ducting sheet
- 410 Fan
- 411 Coupling element
- 413 Lifting plate (RV8, RV12)
- 414 Lifting handle (RV3, RV5)
- 421 Screw
- 422 Nut and bolt
- 453 Motor support
- 454 Screw
- 455 Screw